



Can we give you a lift?

The recently re-introduced Sprinter shuttle already boasts a modern look and space for up to 16 passengers, or eight with two wheelchairs. Now with bi-fold passenger doors plus a flush-side wheelchair lift, it also saves time by speeding shuttle entry and exit.

The Sprinter just successfully completed the seven year Altoona test and still provides unsurpassed fuel savings and requires less scheduled maintenance – all to help your bottom line.

Sleeker style, reliability, comfortable passengers and operators that save money... **it's time you take a closer look at the Sprinter shuttle from Daimler Buses.**

Want to learn more?

Please contact us today
for more information:

Daimler Buses North America

800.882.8054

www.daimler-busna.com

E-mail: sales@dcbusna.com

SPRINTER
Endless Possibilities

VEHICLE SPECIFICATIONS

SPRINTER
Endless Possibilities



- ▶ Length.....24.1-feet
- ▶ Width79.7-inches
- ▶ Height107.5-inches
- ▶ Interior Headroom75-inches
- ▶ Passenger Entry Door38-inch, electric dual-panel
- ▶ Entry Door Height.....80-inches
- ▶ Wheelbase170-inches
- ▶ Fuel Tank Capacity25-gallons
- ▶ Engine.....MB V6 3.0 liters U.L.E.V.
- ▶ Fuel.....Ultra low sulfur diesel
- ▶ Transmission.....MB 5-speed automatic
- ▶ Brakes.....Hydraulic disc brake system
- ▶ Wheels.....16-inch steel
- ▶ GVWR.....11,030 lbs.

SMART CHOICE LIFT PACKAGES

Side wheelchair lift • Rear wheelchair lift

Several layouts are available, including 1 wheelchair, 2 wheelchairs, or 3 wheelchairs positions • ADA compliant

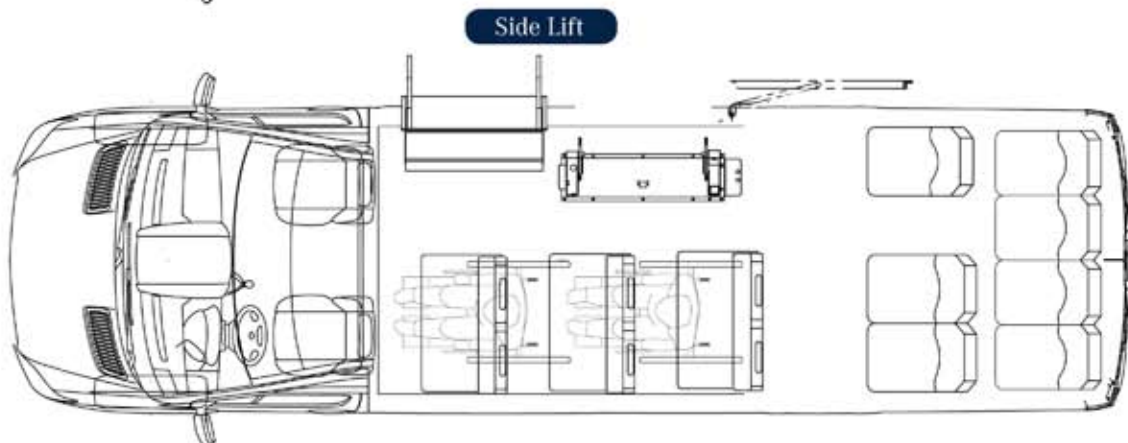
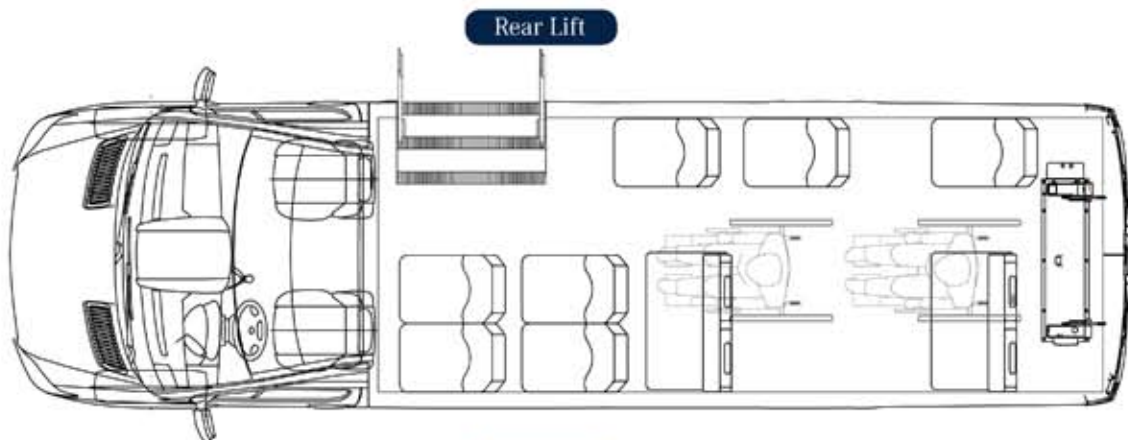

Daimler Buses North America